

# Pulverizer (Fixed)

- Wide jaw opening for work efficient
- Trunnion mounting cylinder for compact design
- High strength and wear resistance materials (Hardox) for reliability
- Speed-up valve for fast work



Description		units	PR050F	PR080F	PR150F	PR200F	PR300F
Weight		kg	580	650	1,370	1,760	2,520
Max Opening Width	A	mm	745	725	840	980	1,110
Overall Width	B	mm	1,050	1,060	1,215	1,445	1,590
Overall Length	C	mm	1,545	1,605	1,665	1,955	2,230
Overall Height	D	mm	470	475	580	655	680
Body Width	E	mm	370	370	450	505	605
Jaw Width	F	mm	255	310	310	320	380
Crushing Force	G	kN	216 (@ 24MPa)	245 (@ 28MPa)	373 (@ 33MPa)	471 (@ 33MPa)	637 (@ 33MPa)
	H	kN	333 (@ 24MPa)	382 (@ 28MPa)	490 (@ 33MPa)	608 (@ 33MPa)	853 (@ 33MPa)
	I	kN	-	-	618 (@ 33MPa)	765 (@ 33MPa)	1,108 (@ 33MPa)
Cutting Force	J	kN	716 (@ 24MPa)	951 (@ 28MPa)	1,393 (@ 33MPa)	1,814 (@ 33MPa)	1,971 (@ 33MPa)
Cutter Length	K	mm	100	100	170	170	200
Allowable Max. System Pressure		MPa	27	30	38	38	38
Recommended Oil Flow		lpm	50 ~ 90	60 ~ 130	110 ~ 200	150 ~ 250	250 ~ 300
Speed-up Valve		-	No	No	Option	Option	Option
Recommended Carrier Weight		ton	4.5 ~ 7.0	5.5 ~ 10	12 ~ 18	20 ~ 28	29 ~ 40
Mounting type		-	P	P	B	P,B	P,B

Pin on Type  
Mounting (P)

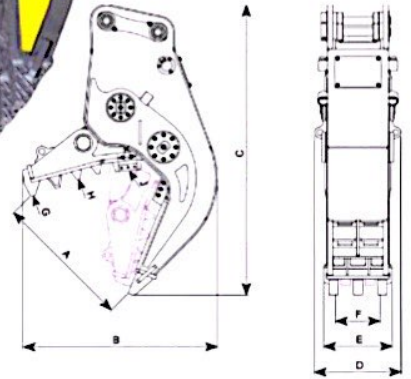

Bolt on type  
Mounting (B)

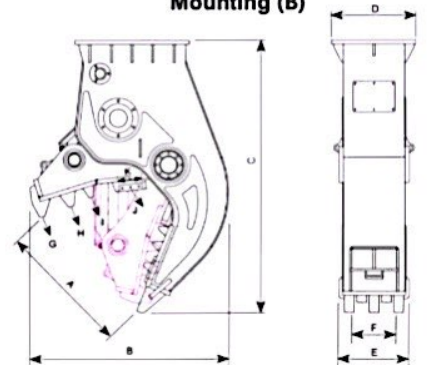

\* Above specifications are subject to change without prior notice